

INDEX GUIDE

1. Description
2. Object
3. Performance
4. Outline explanation
5. Outline
6. Construction description
7. Budget: Engine and construction
8. Currículum
9. Summary

CLEANER MACHINE OF PETROLEUM SPILLED IN THE SEA

DESCRIPTION

TECHNIQUE SECTION

Chapapotera, is already registered with the patent N° 200300030, at the Science and Technology Minister, belonging to the technique sector, like a “superficial cleaning method of the water”, specifically, with the existent devices to clean dirty water with petroleum.

What cleaners machines made up today, is to suction the water. We don't know another method to clean it, because of the physical properties of the fuel. Current possibilities to gather it, are very restricted.

Suction ships just can work in very specific conditions, and even this circumstances, the performance is low. Even this way they don't achieve to separate the petroleum from the water. So we can say that they are not effective.

TECHNIQUE STATE

From the accident of the Torrey Canyon, in 1967, that spread 120.000 tons of petroleum, until last one in 2002, when the Prestige broke in two, have been at least 20 ecological catastrophes related with the spread of petroleum. The “Black tide” have an irreversible effect in the flora and marine fauna, a negative impact in the fishing industry, aquatic reserves and beaches.

Other accidents

Chronological relation of other accidents that caused spill of petroleum.

Year	Accident	Place	Tons
1967	Petrolero Torrey Canyon	UK	130.000
1970	Arrow	Nueva Escocia, Canadá	12.000
1971	Wafra	Suthafrica	40.000
1972	Tamano	Maine, EEUU	400
1974	Metula	Chile	50.000
1975	Jakob Maersk	Oporto, Portugal	88.000
1976	Petrolero Urquiola	La Coruña, Spain	95.000
1976	Argo Merchant	Nantucket, EEUU	5.700
1977	Hawaiian Patriot	Honolulu	95.000
1978	Petrolero Amoco Cádiz	France	234.000
1979	Petrolero Atlantic Empress	Caribe	145.000
1979	Independencia	Bósfor, Turkey	5.000
1979	Plataforma Ixtoc I	Méjico	476.000
1980	Tanio	Isla de Batz, France	6.500
1980	Pozo Petrolífero	Libia	143.000
1983	Assimi	Omán	83.000
1983	Pozo Petrolífero	Irán	272.000
1983	Petrolero Castillo de Bellver	Suthafrica	267.000
1984	Mobiloil	Río Columbia, EEUU	640
1988	Petrolero Odyssey	Canadá	146.000
1988	Nestucca	Washington, EEUU	11.000
1989	Khark 5	Morocco	80.000
1989	Petrolero Exxon Valdez	Alaska, EEUU	37.000
1991	Guerra del Golfo	Golfo Pérsico	816.000
1991	Haven	Genova, Italy	144.000
1991	ABT Summer	Angola	260.000
1992	Petrolero Mar Egeo	La Coruña, Spain	71.000
1992	Oleoducto	Uzbekistan	272.000
1992	Katina P	Mozambique	72.000
1993	Braer	UK	85.000
1994	Rotura de Oleoducto	Russia	104.000
1996	Sea Empress	UK	72.000
1997	Katja	Puerto de Havre, France	187
1997	Nakhodka	Japan	6.200
1999	Erika	Vizcaya Gulf, Spain	20.000
2001	Baltic Carrier	Denmark	2.700
2002	Petrolero Prestige	La Coruña, Spain	77.000

In the next table, we show the quantity of substances spilled in the sea between 1974 – 2001, putting together according to the origin.

OPERATIONS	< 7 tons	7-700 tons	>700 tons	Total
Loads/unloading	2767	299	17	3083
Bunkering	541	25	0	566
Other operations	1167	47	0	1214
ACCIDENTS				
Collisions	163	254	87	504
Beached	222	200	106	528
Chasis fails	562	77	43	682
Fire and explosions	150	16	19	185

It increased the necessity to develop equipment, devices and method to reduce the environmental impact that this kind of accidents produce.

Several inventions has been proposed to solve this problem about gathering and separate the petroleum from water. Some of then, are the kind of inventions with patents N° WO 01/90486, WO 97/01680, WO 03/002823. What they do is to make enter the dirty and contaminate water, in a machine. Once inside, it is treated with different mechanics methods, like traps, places along the conduit for where the water circulate. Finally, the clean water is returned to the sea and the petroleum is put in an appropriate recipient.

This kind of invention has as disadvantage the fact that they have to manipulate big quantity of water, for what it consume a lot of energy, and is a really big machine.

Other kind of inventions proposed in the documents with patents WO 99/06638, WO 99/04101, are those who tries to separate the petroleum by thermal treatment, as good cold as hot. What they look for, is to simplify the oil separation from water. This ones have the same disadvantages that the previous had, and besides, they need hot or cold.

There are others inventions, with patent WO 03/085207, WO 98/39520 and WO 99/35340, who tries to remove the oil using floating barriers, and clean the water by mechanics systems. A variant of this ones (ES 2084249), are those that use movable barriers, tied to one or more dragging boats. They collect the oil and leave it in a “cleaning area”. As a disadvantage of this kind of solution, is the fact that we have to define an area to put the petroleum, transport it to that zone, and clean the oil stick in the barriers.

INVENTION PURPOSE

This invention refers to a new way to gather the oil. It has been conceived and made as an alternative solution to solve the problems that this kind of spills produce in seas and rivers. It allow to pick up the petroleum, with different viscosity, in a easy, fast and efficient way.

This one take the petroleum that is in the surface, because of what is not necessary to pump water, saving energy and requiring smaller spaces for the treatment.

It is made made a cylinder, whose diameter and longitude depend of the performance you want or need to have. This one is partially submerged and has on his edge, a kind of "yokels" or "hooks". When they rotate, pick up the oil and put it in a compartment from where is pumped into the receiving ship.

In case of the fluids are very dense, it is better to cover the yokels with a "case", as a net. They are cleaned by some brushes that are places in the high part of the cylinder in each turn.

Catamaran advantages:

The ship in which the oil is pumped, is better to be a catamaran or like this one. This kind of ships allows to work with bad weather conditions.

Here is a list with some of the reasons for what we recommend this ships:

1. It allow to put the machine in the middle of the ship, protecting it from the waves and letting it works in spite of bad weather condition.
2. The funnel shape, favours the oil canalisation and performance. We can make an additional funnel, stacking in the prow non-contaminations barriers.
3. It has more stability
4. The manoeuvrability is also higher.
5. Has the same storage capacity, with the half of longitude.
6. Accept floodgate in prow and stern.

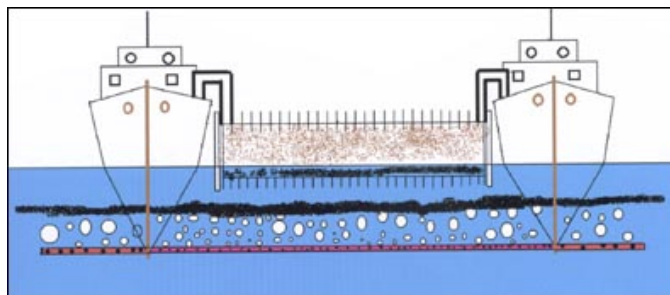

7. Refloat oil spots using compressed air, that is injected throw pipes placed in the keel. This system makes that, the submerged stain refloat, assuring a complete gathering.

8. When the ship needs to go to a distant area, the machine is raised by lateral rails and the boat can sail at max speed.

As we see, this invention allow to collect the petroleum in a efficient and fast way, and at the same time, reduce the damages produced by this kind of contamination.

1. This machine doesn't take water, because is a net.
2. Cleans it self automatically
3. Gather all kind of fluids, the more viscous is better.
4. Low fabrication cost.
5. Up today, there is nothing like it.
6. We have a prototype. This one explain and show the whole process, since it star gathering, until the oil is passed to the catamaran, and the net are cleaned.

Cleaner machine of **Petroleum spilled in the sea**

by LUIS RIOS CARBALLAL **P200300030**

Estimate time to gather the oil
(with the sea in normal conditions)

6 METERS LONG	Thickness: 4 cm	Thickness: 15 cm	Thickness: 40 cm
URNS PER MINUTE	10 TURNS		
COLLECT SPEED	2 KM/H		
THICKNESS OF CHAPAPOTE IN SUSPENSION	4 CM	15 CM	40 CM
QUANTITY PICKED UP BY AN ARRAY OF YOKELS	240 KG	900 KG	2.400 KG
1 TURN OF THE CYLINDER	720 KG	2.700 KG	7.200 KG
1 OUR COLLECTING= 600 TURNS = 432.000 KG	432 TONS	1.620 TON	4.320 TON
1 DAY COLLECTING= 24 hrs = 14.400 TURNS = 10.368.000 KG	10.368 TONS	38.880 TON	103.680 TON
1 WEEK COLLECTING= 168 OURS	72.576 TONS	432.168 TONS	725.760 TONS

12 METERS LONG

1 WEEK COLLECTING= 168 OURS	145.152 TONS	864.336 TONS	1.451.520 TONS
------------------------------------	---------------------	---------------------	-----------------------

Cap. PRESTIGE = 70.000 Tons

**THIS MACHINE PERFORMACE IS ALMOST THE SAME THAT WOULD MAKE
10.000 PERSONS AT THE SAME PERIOD OF TIME**

SHORT DESCRIPTION OF THE DRAW

To complement this description, and in order to help to a better understanding of the characteristics of this machine, we attach a draw in which the advantages are clearly shown.

This draw is a perspective view of the whole machine, except the engine motor, in order to simplify the idea and get a better understanding.

The figure shows a lateral view, pointing out each part

fig.1

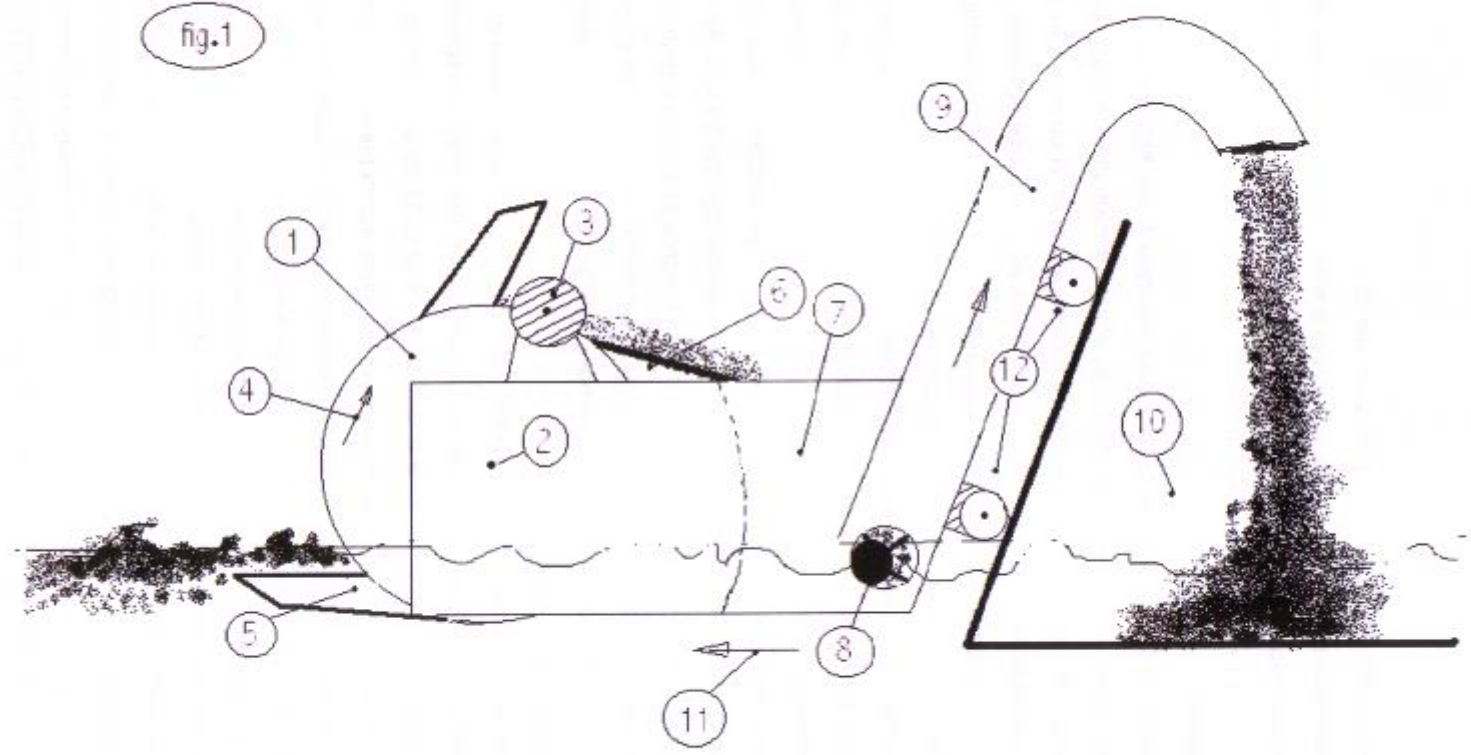

CONSTRUCTION DESCRIPTION

As the image shows, the cleaner machine is build with a cylinder (1) that rotate as the arrows shows (4). It is put ahead, on a wing (2), and is supported by his axis. A temporal storage compartment (7) in witch the petroleum is put before being pumped, by one or more pump bombs (8). The oil pass throw a conduit (9) and is put in the receptor ship. The cylinder, that is activate by a engine motor, has on the surface a lot of yokels or hooks, that when it turns, pick up the oil.

In the upper part of the cylinder, is a brush (6), to clean the hooks when they get this position to let fall down the fuel oil into the storage compartment (7). After this, it is pumped (8) throw the conduits (9) into the recollecting boat.

Quantity, longitude and shape of the hooks, depends of the fuel density. They allow, if it is necessary, to be recovered by cases, as a net.

The wing (2) has 2 parts. First one is where the cylinder is placed and is opened in the bottom, to allow the cylinder contact the water. The second one, is a close compartment because is where the petroleum is placed once is gathered.

The machine size change depending of the recollection performance we want or need to have.

For all this things, to clean this kind of spills, the Chapapotera is the best solution, better than any other invention. First off all, it doesn't use detergent solutions, that increase the damages on waters, either pick up oil with water having a low performance.

We have to remark how simple is the process with this invention, in which the machine works and collect the oil in the place where it is, without having to take it throw other zone, by a complex barriers system.

It is good to be able to build it in different sizes, depending of the necessities and the conditions.

The high performance it reach, considerably reduce the environmental impact and cost, because it can work even at the same the spills is producing.

HYDRAULICS ENGINE FOR A CHAPAPOTERA OF 4 MTS.

OMR 250 motors

Cylinder Engine motor

About 10 rpm

1 Hydraulic Central of	80L	pm	7Kw
1 Lateral hydraulic motor (left)	40L	pm	3Kw
1 Lateral hydraulic motor (right)	40Lpm	3Kw	

Pump motor

1 Hydraulic Central of	120L	pm	24Kw
1 Lateral hydraulic motor (left)	60L	pm	12Kw
1 Lateral hydraulic motor (right)	60L	pm	6Kw

BUDJET

Hydraulic set for the cylinder

1 left motor	6Kw
1 right motor	6Kw
1 central	14 Kw

Total_ 22.000 Euros

Hydraulic set for the pumper

1 left motor	12Kw
1 right motor	12Kw
1 hydraulic central	24Kw

Total 30.000 Euros

Construction: chassis, cylinder, yokel, metallic net, pump, security equipment and protection.

Total 95.000 Euros

TOTAL CHAPAPOTERA = 147.000 Euros

“CHAPAPOTERA” CURRICULIM

Almost 200 inventions, from 12 countries, were exposed in Barcelona (Vilanova i la Geltrú), at the Galactica Fair (International Fair of Inventions) on his 12 edition. It was on September 2003 days 4,5,6 and 7. The Chapapotera was reward with the “Galactica Popular 2003” award.



The Barcelona Forum includes the Chapapotera as one of the hundred better ideas in the world. Clara Cervera, who is in charged of this section, choose this one because it means a big solution to the problems that the spilled oil cause, and help to reflex about this problem. It is good to have same one already constructed, and be able to give a fast response in case of accidents, like Prestige.

INVENTIONS SELECTED BY THE FORUM

Ideas in cubes ELENA MENGUAL (Env. especial) BARCELONA.



Some of the most important inventions for the Humanity, came from very simple ideas. In fact, simplicity is one of the characteristic of many single objects you can see in the Forum, distributed in one hundred exhibitors like "transparent cubes". They are "The cubes for good ideas", and contain selected creations, that are as clear as their containers. Illuminated by a little solar badge that each one have above, you would have to take a long walk, to see them all. Most of the visitors get astonished with the first cube, and that sensation increase while continue sighting. Preval inventions about the use of alternative energy as one way to solve regular problems, mainly in undeveloped countries. Others want to detect and combat bad nutrition in the Third World, a lot of them are consequence of the recycle process, and others look for the way to make life a little less harder, specially for those excluded sectors like "non roof persons" or prostitutes. One of the most notorious invention, was the machine to gather the "chapapote" designed by Luis Ríos. This man propose a new system, faster and more efficient that those ones known up today, to clean the petroleum spilled in the water. It is based on the manual method to gather it -that one used by thousands of voluntiers at the Prestige catastrophe- collecting just the pollutants substances instead of the water. His inventor says that it can makes the work of 10.000 persons and his velocity avoid that the oil could spread, get volatile and contaminate the water.

GALACTICA - Barcelona inventions fair

Chapapotera REWARDED

Jury gives the SILVER MEDAL to the Chapapotera.

The IMAGINARIA 2004 jury, composed by the President of the Enterprise Association of Arousa, José Luis Nogueira Rodríguez, Ángel García Vidal, professor in Mercantile Law for the Santiago de Compostela University, Eladio Grego Gil, investment coordinator for the UNIRISCO Galicia, Coro Gutiérrez, superior technician for the Spanish Office of Patents and Brands, and the director of Associated Pymark, Juan Manuel Sanz Sobrino.

La Voz de Galicia - Arousa (24/05/04

Five thousand persons visit the Imaginaria Fair in Vilagarcía.

The Chapapotera was chosen as the best invention in the fair.

To finish the fair, an award was given to those inventions that the public considered as the better, among the almost seventy presented. First place was for the Chapapotera, that was selected as the best proposition. Luis Ríos Carballal, the author, received the trophy given for the Vilagarcía Trade Chamber. Second and third place was to a water tank that saves 70% of water and a machine to dose paste to fry.



SUMMARY

The cleaner machine of petroleum spilled in the sea, is a gathering system of petroleum with different viscosity in a efficient, fast and simple way. In case of accident it is necessary to recollect the oil as fast as possible to avoid:

1. That it extend
2. That it get volatile contaminating the air.
3. That it get degrade by the waves and water.
4. That it get fractioned complicating the gathering.
5. That it get to shore causing the well knowing damages.
6. The faster it is picked up, in better conditions the oil will be and it can be used by another thing (profitable investment)

In the case that something like Prestige would happen again, doesn't exist any effective system to collect the oil in a fast way.

CHAPAPOTERA, is an auto cleaner net system to gather spilled petroleum. Nets were naturally proved with the Prestige, and was the only thing that works. Otherwise, the oil that is collect, is pumped to another ship.

It solves the contamination risk because is a fast way to gather and prevent the black tide.

It is necessary, to have an international plan to combat this kind of disasters, and this is an effective solution to take with and will be good to put in practice from the first moment.

It not attend just big catastrophes, can be used, depending of the longitude, in different cases.

For this project, we need to be supported by enterprises, institutions and official departments. We think that is not a hard project for the advantages that it gives.

This machine completely solve the problem of the petroleum spilled in sea avoiding the contamination of beaches and shores.



